

External Dimensions (mm)

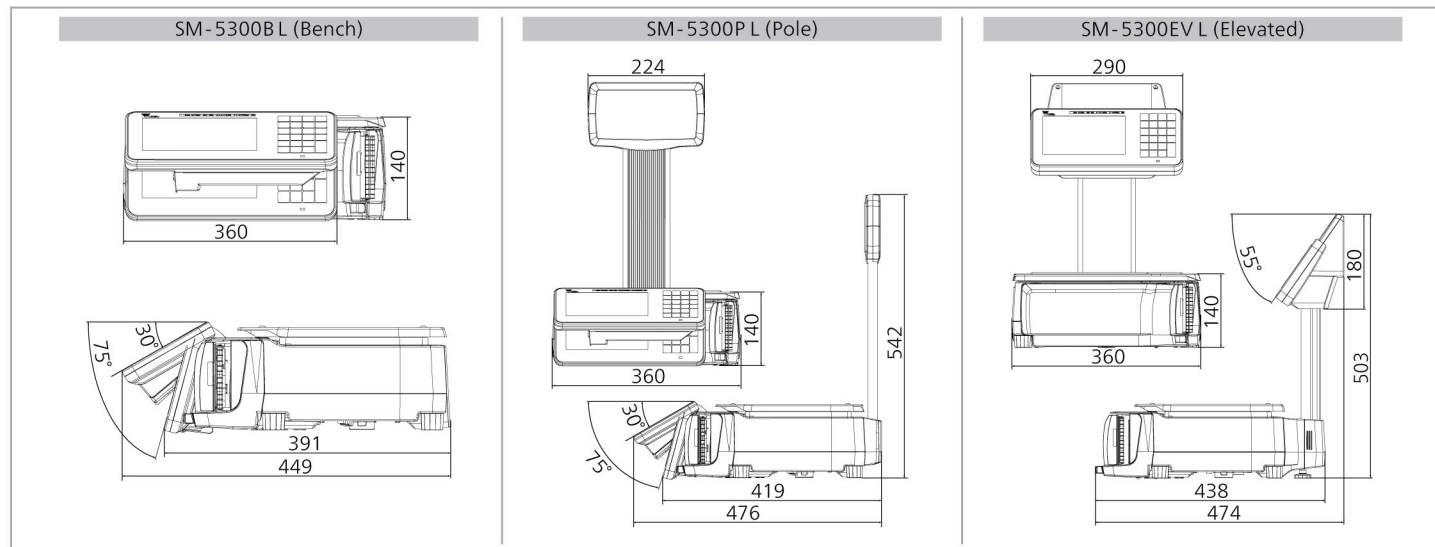

Specifications

Capacity	Max 6kg	Max 15kg / 30lb	Max 30kg
Single Interval	1 / 3,000 e = 2g	e = 5g / 0.01lb	e = 10g
	1 / 6,000 or 1 / 7,500 e = 1g	e = 2g	e = 5g
Capacity	Max 3 / 6kg	Max 6 / 15kg	Max 15 / 30kg
Multi Interval	1 / 3,000 e = 1 / 2g	e = 2 / 5g	e = 5 / 10g

Model	SM-5300B L (Bench)	SM-5300P L (Pole)	SM-5300EV L (Elevated)
Dimension WxDxH(mm)	360 x 449 x 140	360 x 476 x 542	360 x 474 x 503
Operator Display	7" WVGA with Touch (800 x 480)	○	○
Customer Display	7" WVGA (800 x 480)	○	○
Display Resolution	1 / 3,000, 1 / 6,000 & 1 / 7,500		
Number of Preset Keys	23 Alphanumeric Function Keys		
Types	Liner	Linerless With Auto-Cutter	
Roll Diameter	125mm (Max)	95mm (Max)	
Label / Print Width	56mm (Max)	56mm (Max)	
Receipt Paper Width	70mm (Max)	62mm (Max)	
Printing Speed	Up to 150mm / second*	100mm / second*	
Print Resolution	200 dpi	200 dpi	
Power Source	AC 100 / 110 or 220 / 230 / 240 Volts (50 / 60Hz) Auto Switch		
Operating Temperature	-10°C to +40°C		
Humidity	15% to 85% RH		
Standard Interface	Ethernet 10 / 100 Base T, 2 x USB 2.0		
Net Weight	10 kg	11 kg	12 kg
Options	AP-3001G (USB Wireless LAN IEEE 802.11 a / b / g / n), BS-03, TVP-1500Q V2, DL-3700, MD-121, e.Label, InfoTag		
Factory Option	Linerless Printer with Auto-Cutter, Intelligent ID		

** To achieve maximum print speed, high sensitivity thermal paper is necessary. Contact DIGI for details.



CE • Specifications are subject to change without prior notice
• Meet or exceed OIML Class III requirements

DIGI SINGAPORE Pte. Ltd.
4 Leng Kee Road #05-02 / 03 / 04 / 05 / 11
SIS Building SINGAPORE 159088
TEL : +65 6472 2996
SALES: +65 6378 5387
FAX : +65 6863 4614
URL : www.digisystem.com/sg/
E-MAIL : customer_support@sg.digi-group.com

TERAOKA SEIKO CO., LTD.
13-12 Kugahara 5-chome, Ohta-ku,
Tokyo 146-8580, JAPAN
TEL: +81-3-3752-2131
FAX: +81-3-3752-5562
URL: www.digisystem.com

SM-5300L / A / 0217



SM-5300L

System Scale Printer



Searching for a New Balance

World's First Auto-Cutter Weigh Labeller

The world's first weigh-labeller with built-in auto-cutter ensures a smooth cut even after long term use.

Linerless Labels Allow Variable Length And Print Formats

The SM-5300L offers the linerless with built-in auto-cutter functionality that allows printing of labels of variable lengths from a single roll of label.

- Attractive Label
- Reduce Label Cost
- Reduce Logistic Cost



Economical, Efficient & Eco-Friendly

Without the liner, the number of labels per roll will be increased significantly. Operational period is lengthened with few pauses for label changing downtime.

- Reduce Label Waste
- Eco-Friendly
- Increase Operation Efficiency

Watermark Printing

Increase brand awareness and make your product labels more attractive by the versatile use of artistic effects. Use it to your maximum advantage to increase sales and profits.



InfoTag Electronic Shelf Label

Promotional messages, product information and pricing can be displayed on the InfoTag through easy connection with SM-5300L via a wireless base station.

- Wireless Update
- Price Integrity
- Minimum Human Intervention



e.Label With Hi-Touch 2.7" & 4.2"

- Wireless Remote Preset Keys
- 3-Step Operation
- Reduce Error
- High Contrast ePaper Display
- IP-67

Intelligent ID

With the near field identification feature, it eliminates the tedious process of keying in clerk password manually. The scale detects the Intelligent ID tag and automatically registers the clerk.

- Fast Operation
- Reduce Error
- Clerk Operation Log



Integrated Queue & Collection System

The integrated queue and collection system provides shoppers with the convenience to continue shopping while waiting for their turn to be called, effectively reducing walk-aways and increasing sales.

- Q-Alert Application
- Single Department Queue
- Customisable Queue / Collection Ticket

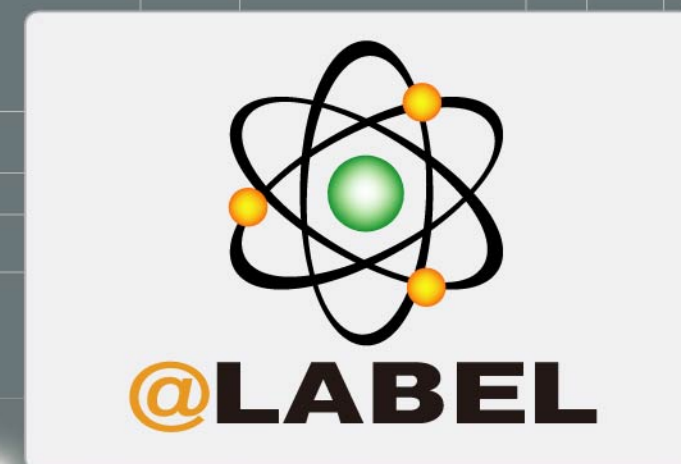

Scale Management Software @LABEL

Information such as sales performance data is automatically collected and stored to one centralized location not only within shops, but also remote sites such as the head office and managers can set, diagnose and maintain remotely.

- DIGI Management Console (DMC)
- Prevent Entry Errors
- Check, Set PLU and Diagnose Anywhere Anytime

Sales Training & Product Information

The 7" operator display equips your sales staff with a wealth of experience by supporting them with advertising content, cross-selling, sales training and product information.

Weigh Labeller With ECR Function

- Receipt Printing
- Multi-Level Discount
- Flex-Key
- Space Saving

Traceability, Security & Networking

Protection from unauthorised manipulation and access is taken care by features such as:

- Audit Trail
- Date and Time Stamp
- Price Override Lock
- Password Protection
- Wireless Network Security (WPA / WEP / LEAP)

The supported network interfaces provide the option of connection via:

- Ethernet 10/100 Based T(TCP / IP)
- Wireless LAN IEEE 802.11 a / b / g / n

Reduce Training Cost with e-Training

Product information, counter layout, cleaning procedure, hygiene and equipment manual can be displayed on demand for staff training.

Interactive Customer Display

The SM-5300L comes with a 7" WVGA customer display that shows useful information for your customers.

- Up Sell
- Cross Sell
- Recipes
- Promotion
- Advertisement



7" WVGA Customer Display